

PALLET LIFTERS

Adjustable Wheeled Pallet Lifters

ADJUSTABLE WHEELED PALLET LIFTERS

- Manufactured to exceed all ASME B30.20 and OSHA regulations.
- Painted safety yellow for increased visibility.
- **ALL** material handling equipment proof loaded and shipped with certification paperwork.
- Durable construction ideally suited to jobsite or warehouse use.
- Made in U.S.A.
- Custom designs available - call for engineering.

Prop 65 – See Page 100

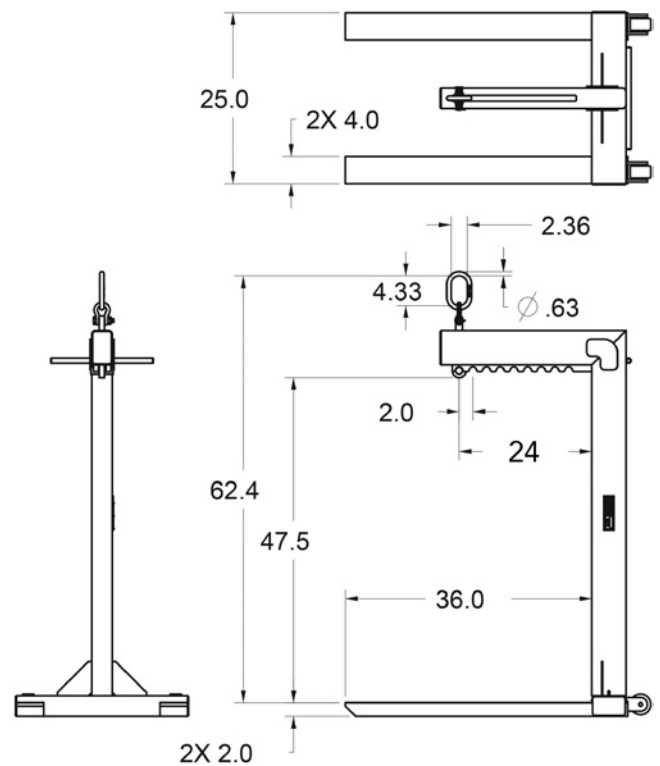
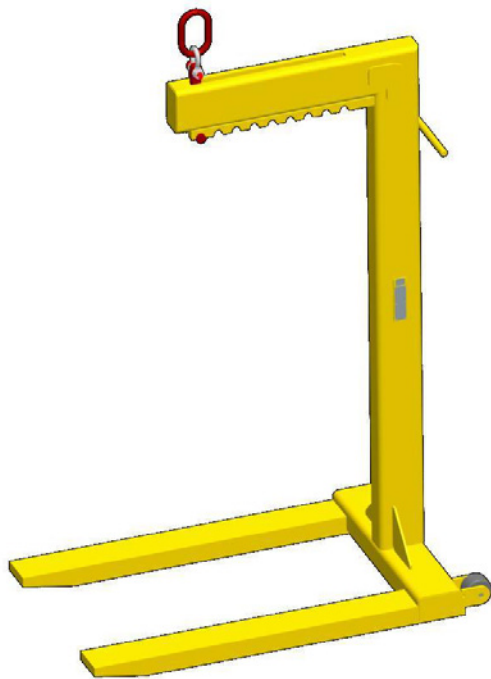

Working Load Limit in Pounds*	Part Number	Weight in Pounds
4,000	14998	330

* Call for specifications on larger sizes and capacities

- Converts crane or hoist into aerial forklift.
- Multiple Lift Bale adjustments.

**** FOR A LEVEL LIFT, THE CENTER LIFTING BAIL MUST BE OVER THE LOADS CENTER OF GRAVITY**