

CONCRETE BARRIER LIFTER

- Manufactured to exceed all ASME B30.20 and OSHA regulations.
- Painted safety yellow for increased visibility.
- Proof loaded and shipped with certification paperwork.
- Durable construction ideally suited to jobsite or warehouse use.
- Made in U.S.A.
- **ALL** lifting equipment individually proof loaded per OSHA requirements.

 Prop 65 – See Page 102

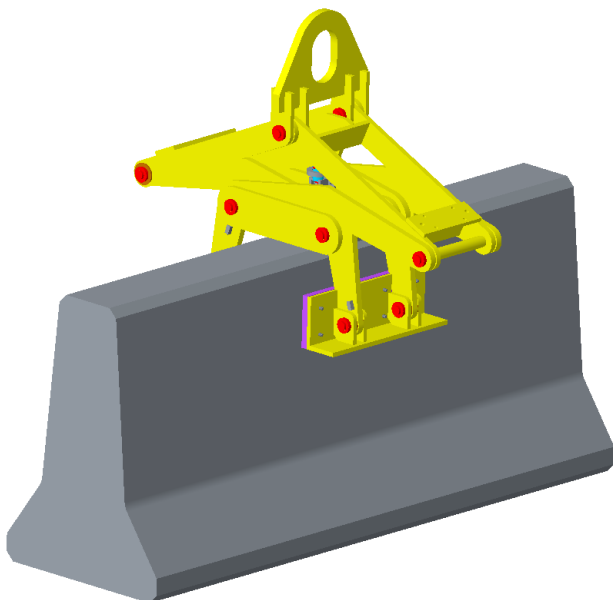

PART NUMBER 19790

- Heavy-duty design to hold up to outdoor environments where barriers are commonly used.
- Stainless steel indexing latch mechanism.
- Rugged gripping pads swivel to conform to load.
- Indexing latch mechanism allows lifter to be held open.

PART NUMBER 19790-31

- Replacement pad installs easily and quickly.

PART NUMBER 19790-40 (Optional)

- Operator Extension Handle keeps ground personnel away from load when adjustment is needed.
- Large lifting eye accommodates crane hook.
- Handles barriers with 6" to 12" width at the top of the barrier.
- 9,000 pound capacity.

Shown with **optional** Part Number 19790-40 Operator Extension Handle on one side.

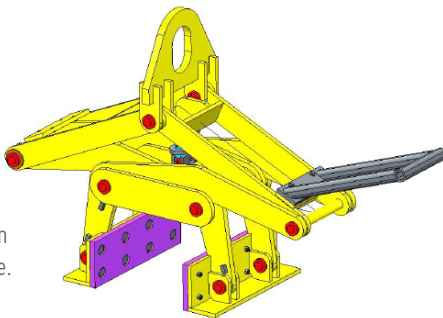

Shown with **optional** Part Number 19790-40 Operator Extension Handle added to both sides.

