

PALLET LIFTERS

- Manufactured to exceed all ASME B30.20 and OSHA regulations.
- Painted safety yellow for increased visibility.
- **ALL** material handling equipment proof loaded and shipped with certification paperwork.
- Durable construction ideally suited to jobsite or warehouse use.
- Made in U.S.A.
- Custom designs available - call for engineering.

Prop 65 – See Page 104

Working Load Limit in Pounds*	Part Number	Weight in Pounds	HR	A	B	C	D	E	F	G	L	W
2,000	14511	190	57.8	2.36	4.33	0.63	24	2	2	48	36	25
4,000	14512	335	58.8	2.36	4.33	0.63	24	2	4	48	36	25
6,000	14513	460	62.8	3.94	7.09	1.03	24	2.5	4.5	48	36	27
8,000	16664	660	65.0	3.94	7.09	1.03	24	3	5	48	36	27

* Call for specifications on larger sizes and capacities

**** FOR A LEVEL LIFT, THE CENTER LIFTING BAIL MUST BE OVER THE LOADS CENTER OF GRAVITY**

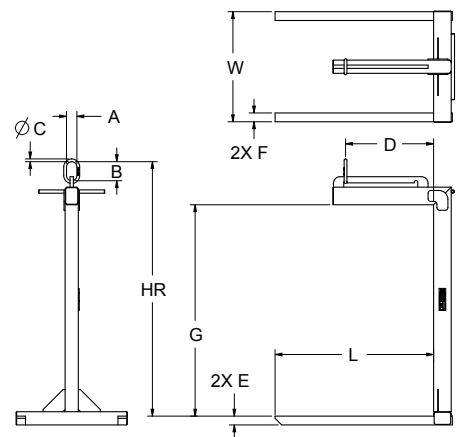

Converts crane or hoist into aerial forklift.

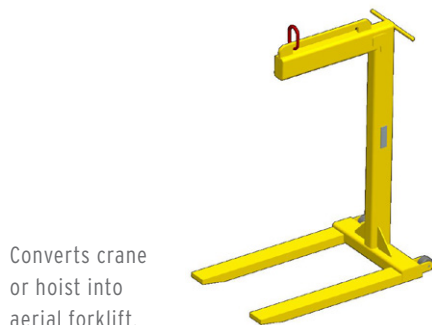

Converts crane or hoist into aerial forklift.

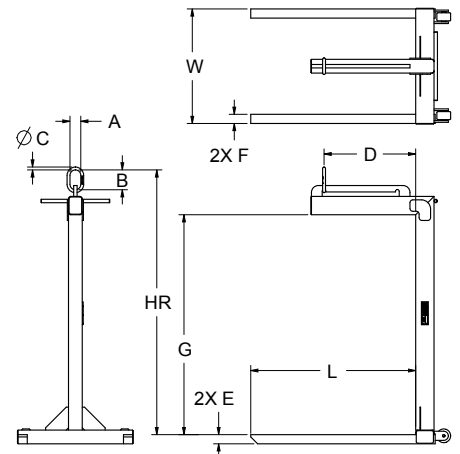

Working Load Limit in Pounds*	Part Number	Weight in Pounds	HR	A	B	C	D	E	F	G	L	W
2,000	14538	190	57.8	2.36	4.33	0.63	24	2	2	48	36	25
4,000	14537	335	58.8	2.36	4.33	0.63	24	2	4	48	36	25

* Call for specifications on larger sizes and capacities