

## PALLET LIFTERS

### PALLET LIFTERS

- Manufactured to exceed all ASME B30.20 and OSHA regulations.
- Painted safety yellow for increased visibility.
- **ALL** material handling equipment proof loaded and shipped with certification paperwork.
- Durable construction ideally suited to jobsite or warehouse use.
- Made in U.S.A.
- Custom designs available - call for engineering.

 Prop 65 – See Page 104

Working Load Limit in Pounds*	Part Number	Weight in Pounds	HR	A	B	C	D	E	F	G	L	W
2,000	<b>14631</b>	190	57	4	5	1	24	2.5	2.5	48	48	25
4,000	<b>14630</b>	760	59	4	5	1	24	2.5	4	48	48	25
6,000	<b>14629</b>	965	62	4	7	1.5	24	3	5	48	48	27

\* Call for specifications on larger sizes and capacities

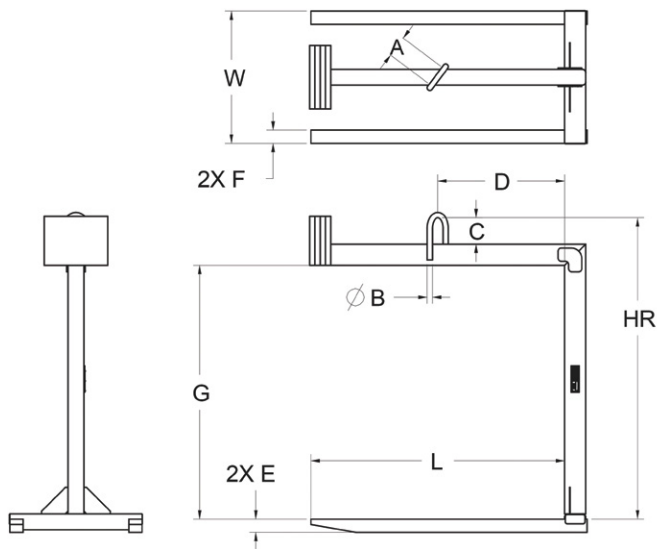

- Converts crane or hoist into aerial forklift.
- Counter balance allows lifter to hang level when empty.

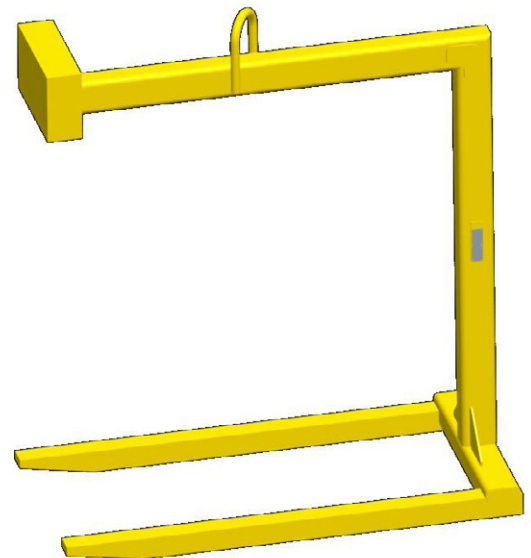

\*\* FOR A LEVEL LIFT, THE CENTER LIFTING BAIL MUST BE OVER THE LOADS CENTER OF GRAVITY