

- Manufactured to exceed all ASME B30.20 and OSHA regulations.
- Painted safety yellow for increased visibility.
- **ALL** Coil Lifters proof loaded and shipped with certification paperwork.
- Durable construction ideally suited to jobsite or warehouse use.
- Made in U.S.A.
- **ALL** lifting equipment individually proof loaded per OSHA requirements.

Prop 65 – See Page 112

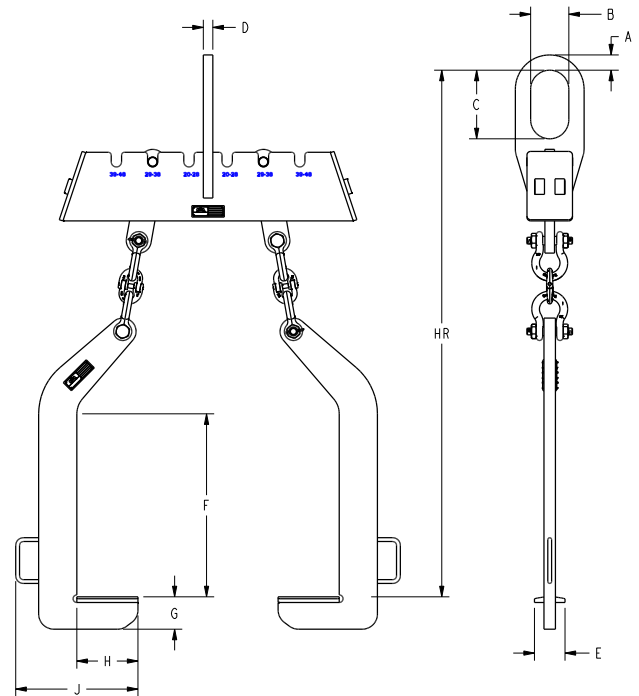
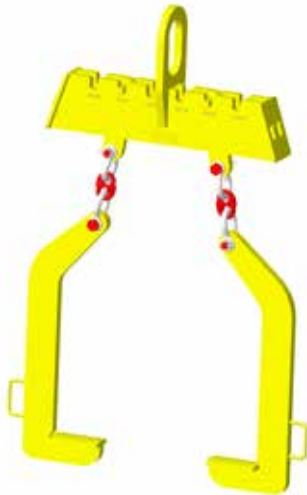

Part Number	Working Load Limit in Pounds*	Coil Range Beam Width Settings	Min / Max Coil Width	A	B	C	E	E	F	G	H	J	HR	Weight
24800	20,000	20"-28" 29"-38" 39"-48"	20"-48"	2	5	9	1.25	4	24	4.25	8	16	69	545
24892	30,000	20"-28" 29"-38" 39"-48"	20"-48"	2	5	9	1.25	4	28	4.5	8	16	73	555
24894	40,000	24"-32" 33"-42" 43"-52" 53"-60"	24"-60"	2.5	8	9	1.25	4	30	4.75	8	16	80	785

\* Call for specifications on larger sizes and capacities