

- Manufactured to exceed all ASME B30.20 and OSHA regulations.
- Painted safety yellow for increased visibility.
- Do not side load above angles of 45° from vertical.
- Durable construction ideally suited to jobsite or warehouse use.
- Made in U.S.A.
- Custom designs available - call for engineering.
- **ALL** lifting equipment individually proof loaded per OSHA requirements.

Prop 65 – See Page 112

- Refer to side loading table below for reduction factors for side loading applications.
- Clamps to be used for lifting, pulling or as an anchor point.
- Ratings apply to clamps only. User is responsible for engineering calculations for all support steelwork.

WARNING: All clamps must be correctly applied to the beam by a competent person and fully hand tightened. If in doubt, contact M&W for recommendations.

Reduction in Working Load Limits when side loads are applied				
Angle from Vertical	0°	0 - 15°	15 - 30°	30 - 45°
Reduction factor	none	20%	35%	50%

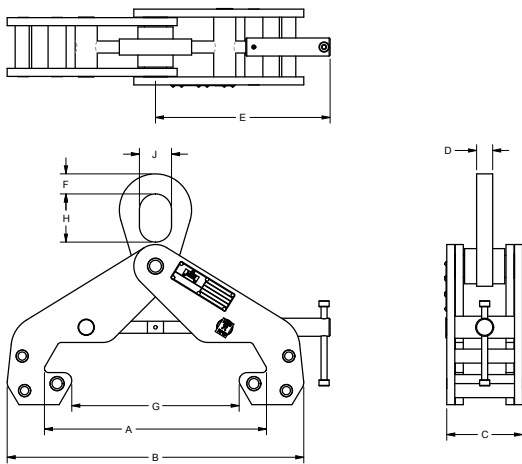

Working Load Limit in Pounds*	Part #	A	B	C	D	E	F	G	H	J	Weight	Maximum Flange Thickness	Maximum Flange Width	Minimum Flange Width	Maximum Slip Over Width
15,680	13659	16.02	20.92	4.72	1.00	10.88	1.25	12.94	3.00	1.75	34.1	1.25	13.75	4.50	13.38
22,400	13674	16.02	20.92	4.72	1.25	10.88	1.50	12.94	3.75	2.50	43.1	1.25	13.75	4.50	13.38

*Call for specifications on larger sizes and capacities.