

FORKLIFT ATTACHMENTS

Forklift Lifting Beams Outside Hooks

- Manufactured to exceed all ASME B30.20 and OSHA regulations.
- Painted safety yellow for increased visibility.
- **ALL** forklift attachments proof loaded and shipped with certification paperwork.
- Durable construction ideally suited to jobsite or warehouse use.
- Check with manufacturer of your forklift for load capabilities.
- Made in U.S.A.
- Custom designs available - call for engineering.
- Includes forklift restraining tabs.
- Carrying handle for easy placement by personnel - **HANDLE NOT INTENDED FOR LIFTING LOADS.**

 Prop 65 – See Page 112

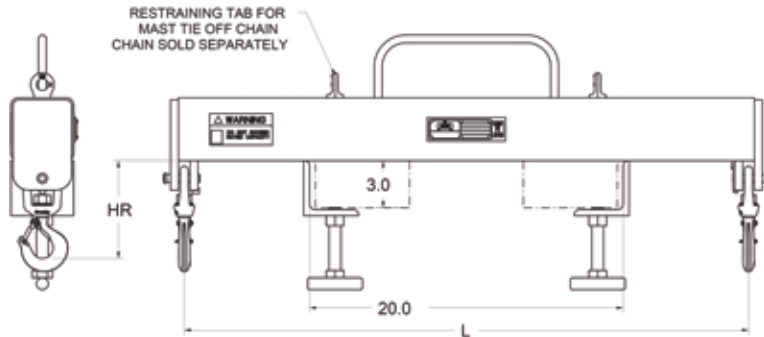

**SOLD WITH HOOKS
AS SHOWN**

Working Load Limit in Pounds*	Part Number	HR	L	Weight
5,000	12343	6.2	36	49
10,000	12363	7.3	36	76
14,000	16523	8.8	36	90
22,000	16524	11.0	36	125

* Call for specifications on larger sizes and capacities

OPTIONAL MAST TIE OFF CHAIN:

Part Number	
20410	Mast Tie Off Chain - 8' Long

WARNING: M&W fork beams, fork booms, fork pockets and other lift attachments are modifications or additions that affect capacity and/or safe operation of forklifts (powered industrial trucks) and shall not be used without prior written approval from the forklift manufacturer. Capacity, Operation, Maintenance instruction plates, tags, and/or Decals shall be changed accordingly and not provided by M&W.

Reference OSHA 1910.178 | Any forklift attachment must use a tie off restraint to prevent from sliding off forks, sold separately