

- Manufactured to exceed all ASME B30.20 and OSHA regulations.
- Painted safety yellow for increased visibility.
- Durable construction ideally suited to jobsite or warehouse use.
- Ratchet strap secures drum
- Used with 30 & 55 gallon fiber, steel or plastic drums
- Vertical lifting only
- Shackles not included
- Maximum drum dia is 24.63
- Made in U.S.A.
- Custom designs available - call for engineering.
- **ALL** lifting equipment individually proof loaded per OSHA requirements.

 Prop 65 – See Page 112

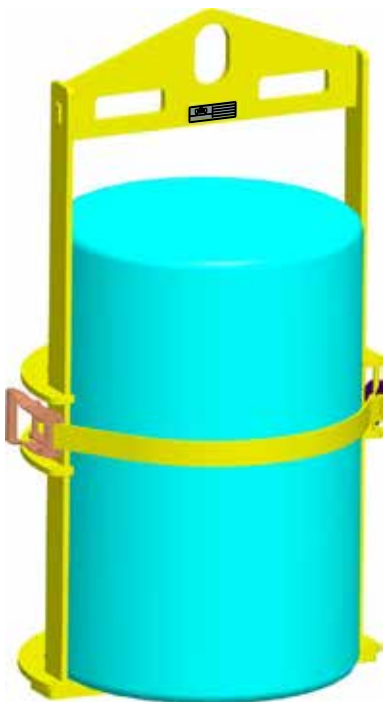

Part Number	Working Load Limit	Weight
23589	1,000	160

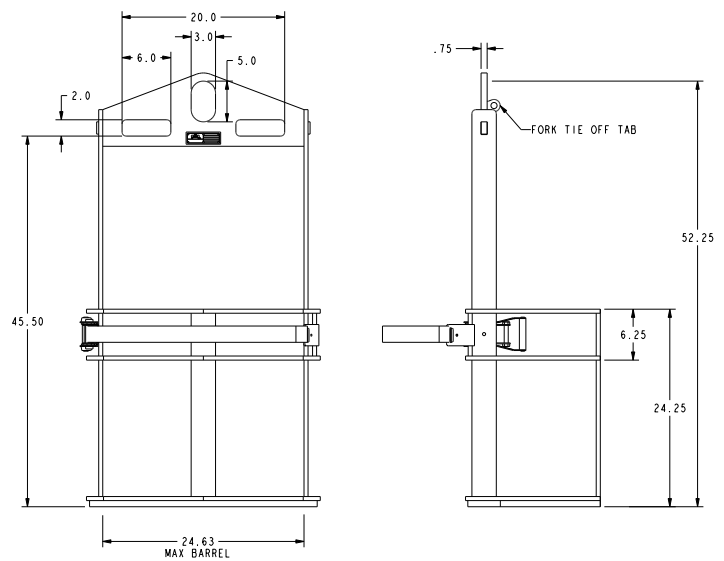

OPTIONAL MAST TIE OFF CHAIN:

Part Number	
20410	Mast Tie Off Chain - 8' Long