

- Manufactured to exceed all ASME B30.20 and OSHA regulations.
  - Painted safety yellow for increased visibility.
  - Removable bottom lifting bars slide through pallet.
  - Expanded metal side cage.
  - 4 point top lift, with slig provided by others.
  - Do not use with damaged or broken pallets
  - Do not exceed working load limit
  - Made in U.S.A.
- All rigging and shackles by others.
  - User must determine if pallet is capable of being lifted with this device.
  - **ALL lifting equipment individually proof loaded per OSHA requirements and shipped with paperwork.**

Prop 65 – See Page 112

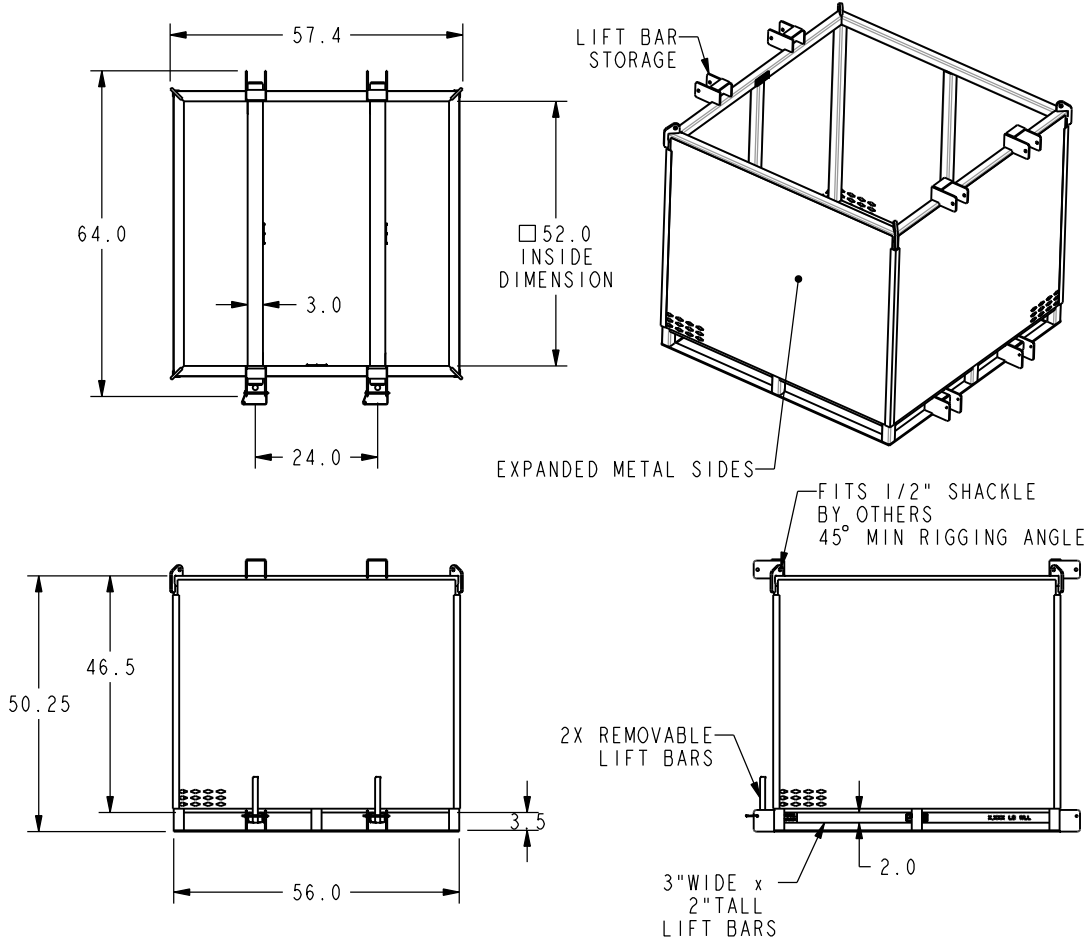

Part Number	Working Load Limit	Weight	Inside Clearance
25504	4,400	660	52"