

- Manufactured to exceed all ASME B30.20 and OSHA regulations.
- Painted safety yellow for increased visibility.
- **ALL** forklift attachments proof loaded and shipped with certification paperwork.
- Durable construction ideally suited to jobsite or warehouse use.
- Easily moves trailers.
- Check with manufacturer of your forklift for load capabilities
- Made in U.S.A.
- Includes forklift restraining tabs.

Prop 65 – See Page 112

Part Number	Insert	Max Tongue Weight - LBS	Max Rolling Trailer Weight - LBS	Weight
19037	None (with pin)	N/A	N/A	115
23332	3 Way Ball, 1 7/8", 2", 2 5/16"	600	6,000 7,500 10,000	135
23333	Pintle Mount, 4 bolt 1/2" dia x 3 3/8" x 1 3/4"	3,000	16,000	135

**RESTRAINING TAB FOR MAST TIE OFF CHAIN
CHAIN SOLD SEPARATELY**

OPTIONAL MAST TIE OFF CHAIN:

Part Number	
20410	Mast Tie Off Chain - 8' Long

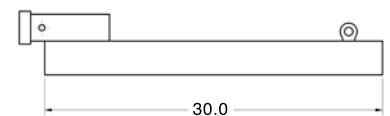
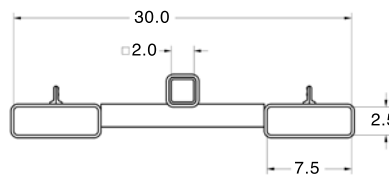
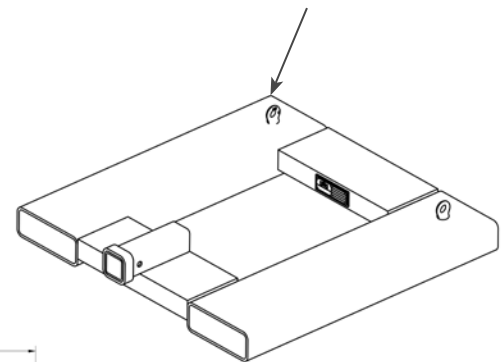

WARNING: M&W fork beams, fork booms, fork pockets and other lift attachments are modifications or additions that affect capacity and/or safe operation of forklifts (powered industrial trucks) and shall not be used without prior written approval from the forklift manufacturer. Capacity, Operation, Maintenance instruction plates, tags, and/or Decals shall be changed accordingly and not provided by M&W.

Reference OSHA 1910.178 | Any forklift attachment must use a tie off restraint to prevent from sliding off forks, sold separately